

# RO-MAN

## REVERSE OSMOSIS SYSTEM INSTALLATION GUIDE 50, 75 AND 100 GPD 3 STAGE RO SYSTEM

PLEASE READ THIS ENTIRE GUIDE PRIOR TO BEGINNING INSTALLATION.

IF AT ANY TIME YOU ARE UNSURE HOW TO PROCEED

PLEASE CONTACT THE SUPPORT TEAM [HELPDESK@RO-MAN.COM](mailto:HELPDESK@RO-MAN.COM)



THIS WATER SYSTEM HAS BEEN DESIGNED FOR QUICK AND SIMPLE INSTALLATION AND MAINTENANCE. BY CAREFULLY READING THIS INSTRUCTION MANUAL AND FOLLOWING THE OPERATIONAL GUIDELINES YOU WILL ENSURE A SUCCESSFUL INSTALLATION AND RELIABLE OPERATION. ROUTINE MAINTENANCE IS ESSENTIAL TO THE LONGEVITY AND PERFORMANCE OF THE SYSTEM. FILTERS SHOULD BE CHANGED EVERY TWO TO SIX MONTHS DEPENDING ON THE QUALITY OF THE FEED WATER SUPPLY AND THE QUANTITY OF WATER PRODUCED.



THIS WATER SYSTEM HAS BEEN DESIGNED FOR QUICK AND SIMPLE INSTALLATION AND MAINTENANCE. BY



**CAUTION**

**DO NOT USE THIS SYSTEM WHERE THE WATER IS  
MICROBIOLOGICALLY UNSAFE OR OF UNKNOWN QUALITY.**

## CONTENTS

	Page
Schematic of the Standard 3 Stage System	3
Illustration of the Standard 3 Stage System	4
Reverse Osmosis How It Works	5
Installation Kit Contents	6
Starting your Installation	7
Installing Supply Feed	7
Fitting the Pipes	8
Fitting the Membrane	9
Flushing the Filters	10
Flushing the Membrane	10
Turning off your RO System	11
Options / Accessories	11
Maintenance	12
The Thin Film Membrane Spec	13
The Thin Film Membrane Rejection Characteristics	14
The Thin Film Membrane Performance & Correction Factor	15
Trouble Shooting	16

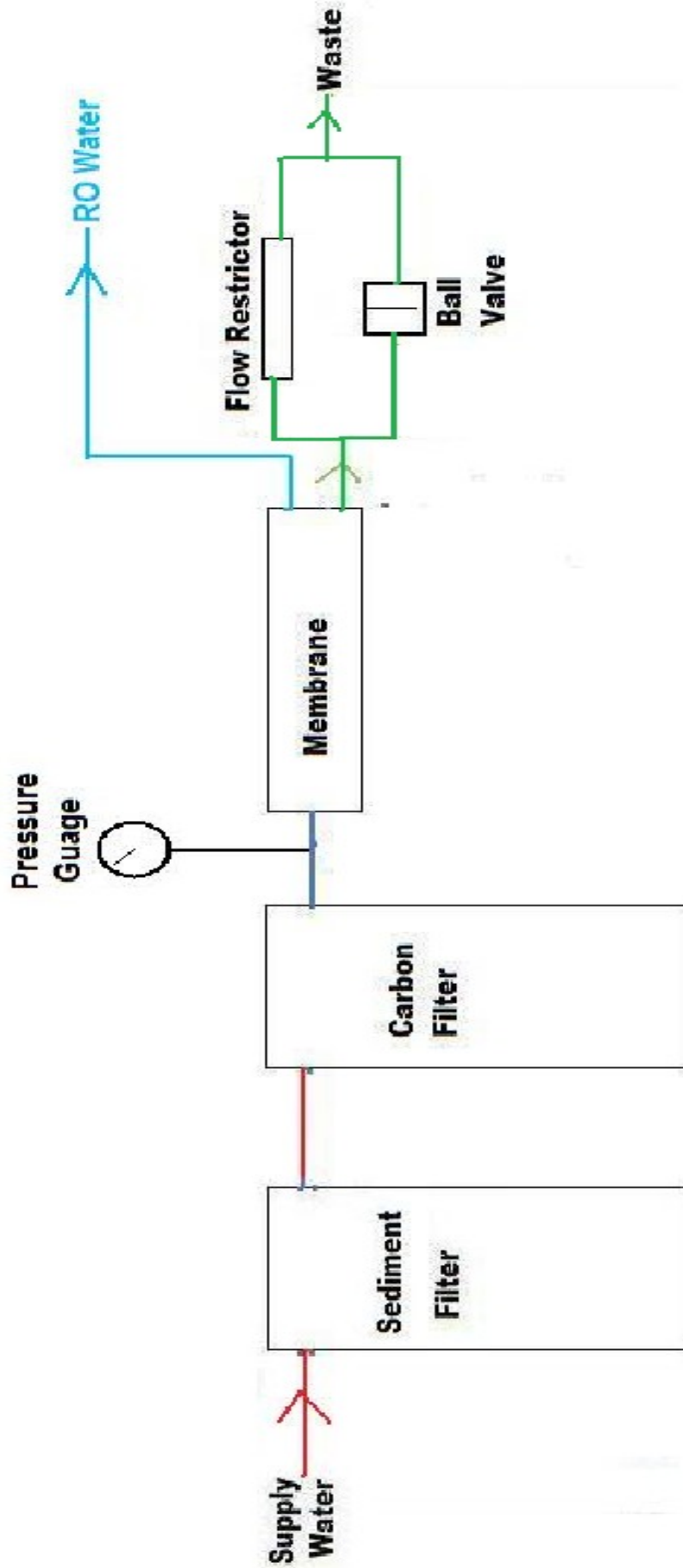

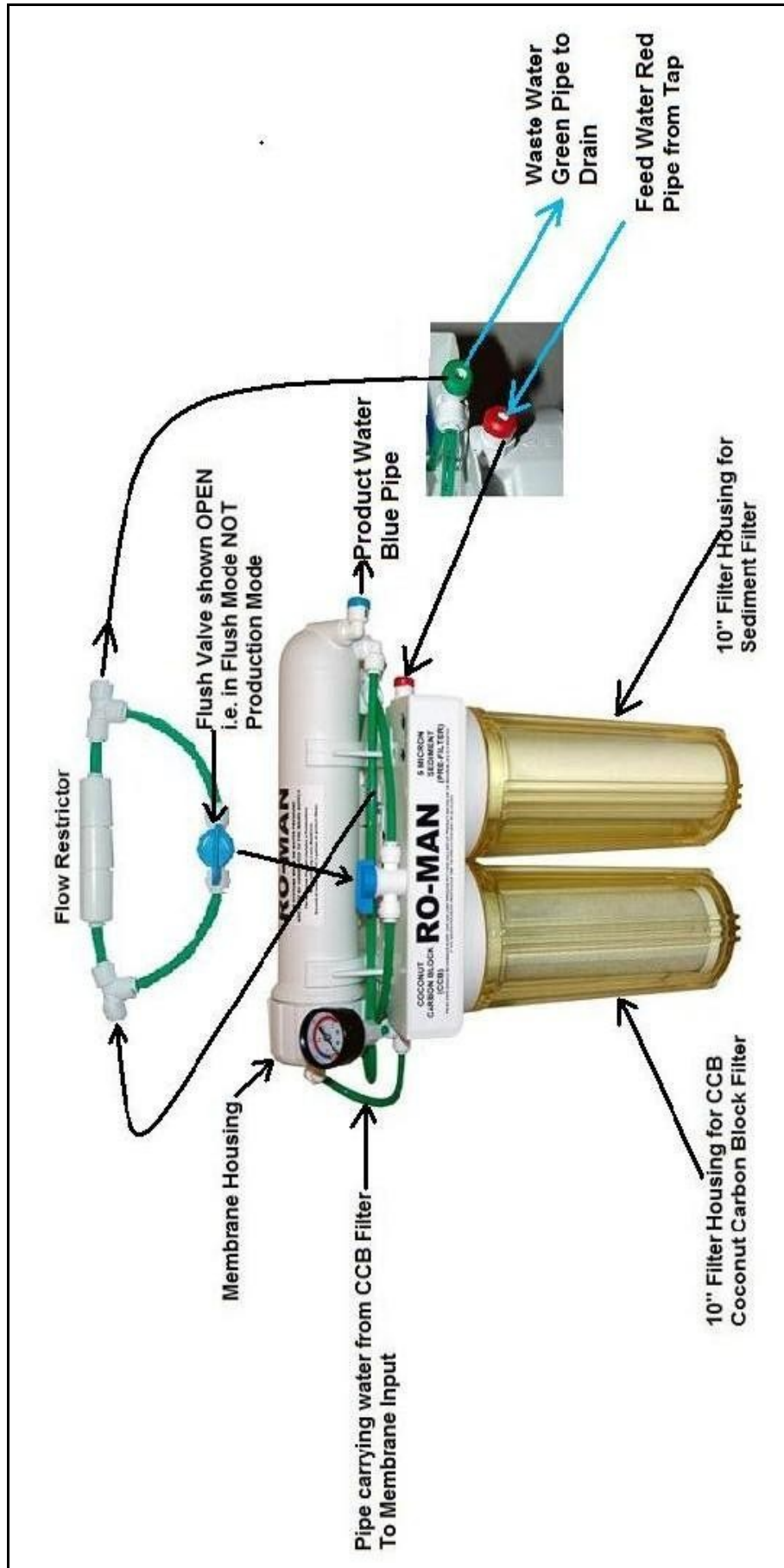



## Reverse Osmosis How It Works



**What is Reverse Osmosis?** At its most basic, it is a water separation device. Water is passed under pressure over a semi-permeable membrane. The holes in the membrane are large enough to allow water molecules through but not large enough to allow other larger molecules (dissolved solids) through. An RO-MAN system will remove 92 – 98% of the “Total Dissolved Solids” (TDS) from the water. By adding a De-ionisation stage we can remove 100% of the TDS from the water.

**How does the R.O. Filter work?** I’m sure that most people remember learning about osmosis in school. Just to refresh: It is the process by which clean water is attracted to dirty water when separated by a semi-permeable membrane. By applying pressure we can reverse the process - Hence the name “Reverse Osmosis”.

**What are the Stages in an R.O. System?** The membrane is the heart of the system & needs to be protected. This is done by pre-filtration. Depending on the size of your system RO-MAN systems have two or three pre filters. For this purpose we are looking at a 3 stage 50 gallon per day system.

Stage 1: 5 Micron Sediment Filter – for the removal of sediments such as dirt, sands and rust. We do not use a 1 micron filter as we find that they block very easily and this affects the performance of the system.

Stage 2: Carbon Block Filter – This is used for the removal of chlorine, some heavy metals & other contaminants. RO-MAN use a top quality roasted coconut husk activated carbon block filter.

Stage 3: The Membrane– As mentioned earlier this is the heart of the system. An RO-MAN membrane removes 92-98% of the Total Dissolved Solids in the water by the process described earlier. As it is the heart of the system it is important to have the best possible membrane. RO-MAN uses a “Thin Film Composite” membrane made under licence for us in the USA by a leading membrane manufacturer..

After the water has passed through the membrane you have two options.

- 1 – Use the water as it is.
- 2 – Further polish the water using De-ionization

**De-ionization** – RO-MAN membranes remove 92 – 98% of the TDS in the water. For some applications, such as drinking water this is perfectly adequate. For other applications such as Marine fish keeping and window cleaning a TDS of zero is necessary. To attain a 0 TDS we use a De-ionization (DI) Resin. This is a granular substance that acts like a sponge and sucks the remaining TDS out of the water until it reaches capacity. You should monitor the life of Resin with a TDS meter.

**STANDARD INSTALLATION KIT CONTENTS :-**

**3 STAGE REVERSE OSMOSIS SYSTEM**  
**REVERSE OSMOSIS MEMBRANE (NOT FITTED)**  
**SEDIMENT FILTER (FITTED)**  
**CARBON FILTER (FITTED)**  
**2M RED PIPE**  
**2M GREEN PIPE**  
**2M BLUE PIPE**  
**SADDLE VALVE MAINS 1/4"**  
**ROLL PTFE TAPE**  
**FILTER WRENCH**

## STARTING YOUR INSTALLATION

### **Preparation**

Determine the location for the installation of the system. Avoid locations where the system might come in contact with hot water pipes, other hazards or is exposed to extreme cold, an RO membrane will be damaged by frost.

Determine the location for the discharge of the waste water.

Determine the location of the cold water pipe. To assure you are using the cold water line, turn on both the hot and cold tap. After the water is warm to the touch, feel the pipes under the sink. It will be easy to identify the hot and cold pipes.

## INSTALLING SUPPLY FEED

### **SHUT OFF THE WATER**

Locate the water shut-off valve for the cold water feed line of your mains supply. Accidentally hooking up the system to the hot supply line will permanently damage the membrane (See Conditions for operation). Close the cold water valve. Turn on the cold water tap only to assure that the line is completely shut off and the line is drained... if no shut off valve is located under the sink, turn off the main supply at the entry to the house.

Before starting to fit the saddle clamp to the cold water supply ensure that the valve is fully open i.e. when looking down the wing nut is turned anti clockwise as far as it will go (don't force it).

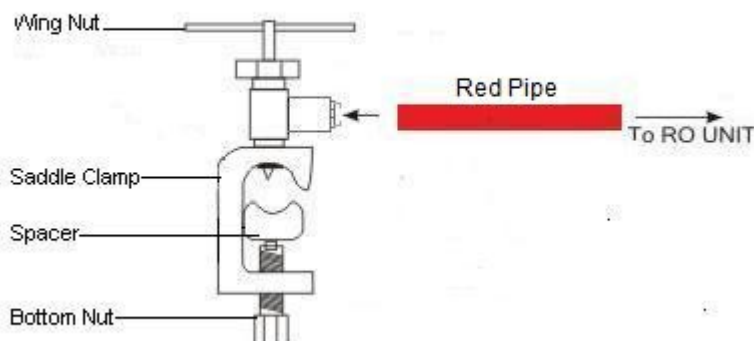

Now fit the saddle valve to the 9 or 15mm copper cold water supply pipe ensuring that the spacer is fitted appropriately, so that the spacer fits snugly to the pipe, then tighten the lower bolt with a spanner.

You can now connect the red 1/4" pipe, which will feed the RO system, by simply pushing it into the saddle valve as far as it will go and then gently pulling back to ensure that it is gripped securely.

NOT NOW but when you are ready to feed water to the RO system you turn the wing nut fully clockwise which will cause a spike to be driven into the copper pipe and then anti clockwise to start the flow of water.



Please note do not use this valve on a regular basis to turn the system on and off, a ball valve should be used for this.

### FITTING THE PIPES

#### NOTE ON PUSH FIT CONNECTIONS:-

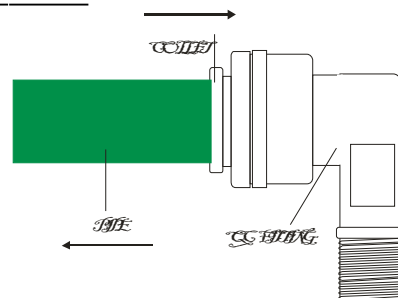

The Push Fit Connectors are opened by pushing down on the collet ring with two fingernails and pulling the hose at the same time. If your nails are not user friendly, then use a pair of pliers, a small spanner or any tool that can apply pressure on both sides of the Quick Connectors Collet

#### **The Red Pipe**

Connect one end of this to the saddle clamp that you have previously fitted to your cold water pipe and after cutting this red pipe to an appropriate length connect it to the red capped inlet to your Sediment Filter housing found at the top right of the RO unit and marked with an up arrow and the word "IN". Do NOT turn the water on yet!

#### **The Blue Pipe**

Connect one end of this to the membrane housing (see page 3) and the other end of this pipe to your collection vessel.

#### **The Green Pipe**

One end of this to be attached to a suitable waste water discharge point, typically this will be a 36mm white plastic domestic pipe.  
Should this be the case a 6mm hole drilled into the top of the pipe will accept the RO system waste pipe, this can be sealed with silicone.  
An alternative is to use the same pipe as the washing machine.  
The other end should be run to the vicinity of the CCB filter housing but do not cut this yet as it will eventually have to be connected to the membrane housing.

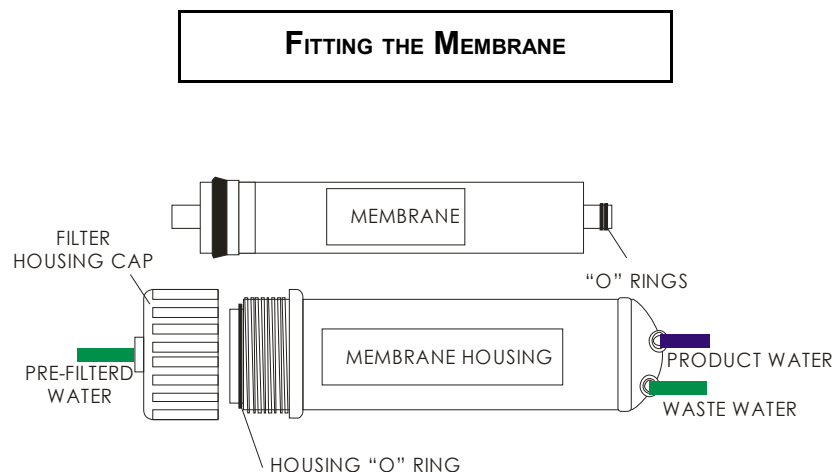

#### UNPACK THE MEMBRANE



**DO NOT REMOVE THE WHITE STICKY TAPE OR THE PLASTIC WRAPPING FROM AROUND THE MEMBRANE!**

The membrane has a plastic core in the centre of the membrane material. You will see there are two small black o-rings. It is recommended that both the two small black O-rings and the large black seal are given a VERY light smear of petroleum jelly such as Vaseline to aid insertion. Holding the housing unscrew the housing cap completely and insert the membrane with the two small, black O-rings first, it will stop at the large black gasket seal located on the outer edge of the membrane material. Push the membrane into the housing sometimes it's a tight fit so push with adequate force. You will feel it "seat" into the housing.

Once the membrane is seated properly, make sure the housing "o ring" is fitted and moist. Then screw the housing cap firmly onto the housing.

#### FLUSHING THE FILTERS



(YOU COULD DAMAGE THE MEMBRANE IF YOU DO NOT DO THIS)



Disconnect the pipe from the CCB filter housing (see page 3) and connect the supplied green pipe to this connector. The other end to go to where the waste water will be discharged

Switch the water supply back on by opening the saddle valve (see previous Installing Supply Feed) by slowly turning the saddle valve wing nut counter clockwise until fully open. Check seal for leakage, If necessary tighten the bottom nut lightly.

**Now allow at least 2 UK Gallons of water to run through the system**

### FLUSHING THE MEMBRANE

Turn the water off.

Disconnect the green pipe from the back of the CCB filter housing and connect it to the Tee piece with the green cap found on the top right of the RO system (see Page 3). The pipe that you previously disconnected from the CCB filter housing and which runs to the pressure gauge and membrane housing should now be reattached to the filter housing.

Ensure that the Flush Valve in the green pipe at the top of the system is in the "Production" setting, turn the supply water back on at the saddle valve and allow the system to run until 5 gallons of production water has been produced. During this period check the complete system for leaks.



**IMPORTANT NOTE:**



**Do Not Use the First 5 Gallons Production Water**

**DO NOT DRINK THIS WATER**

**This first 5 gallons removes the factory Installed sanitizing solution from the entire system**



**Now get a good light and check over the entire system carefully.**

When the system is under full pressure is when any tiny leaks will occur if they are going to so remember to keep your eye on it for a couple of days!

Remember the one and only time you will do this. Expect a couple of bugs They Will Be Worked Out!!!

**Turning off your RO System**

To manually turn off your RO system it is recommended that a 1/4 inch Ball Valve is fitted in the red supply pipe. Should you anticipate frequently moving your system then a ball valve should also be fitted to the blue production pipe and the green waste pipe, this will ensure that your membrane is kept wet at all times.

To have the system turn off automatically when the collection vessel is full you can fit an Auto Shut Off Kit which comes with its' own instructions.

Should you have a pump fitted to your system you can fit a High Pressure Switch, Float Valve and Solenoid

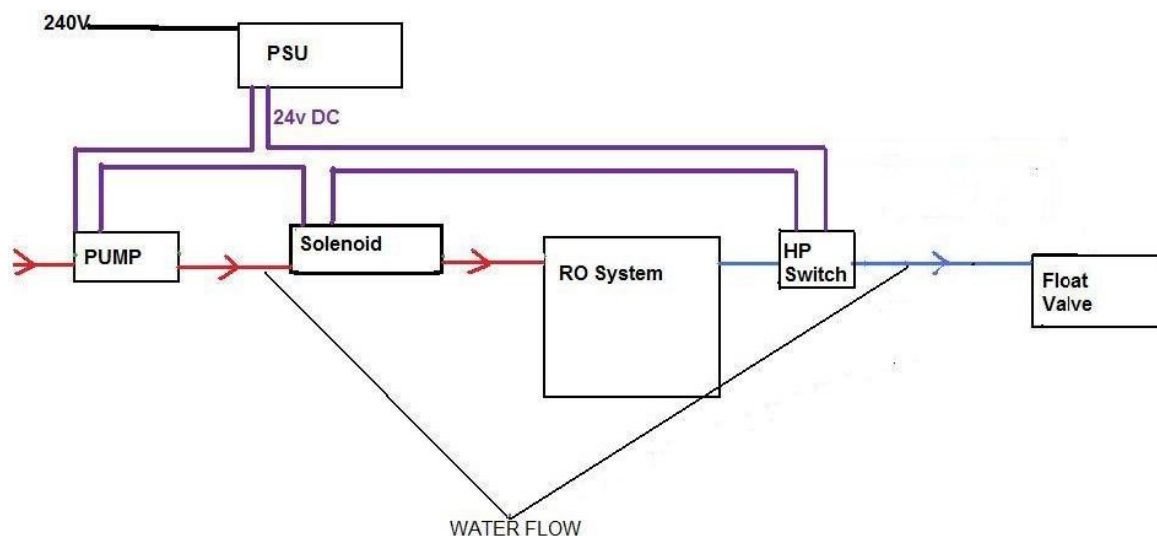

All the part mentioned in these instructions can be easily found in the [www.ro-man.com](http://www.ro-man.com) shop by typing the name of the part in the "Quick Find" search box that can be found at the bottom left of the page.

### RO-MAN OPTIONS / FITTED ACCESSORIES

#### **PRESSURE GAUGE – Fitted as standard**

There are two reasons for fitting a pressure gauge :-

1. To read the water pressure in order to check whether it is within specification. System pressure is very important too little pressure will make the production rate very slow and too much pressure will make the seals fail  
Low pressure will make the TDS higher e.g. a system running at 65 psi may have a TDS of 5 while the same system running at 40psi could have a reading as high as 15.
2. To work out when the sediment filters are blocked.

#### **DEIONISATION (DI) - an option**

Deionisation is used to polish the water making it 100% pure. TDS reading should be near zero if using a DI unit.



**Water that has passed through a DI unit IS NOT suitable for drinking**

### **TDS (TOTAL DISSOLVED SOLIDS) METER- an option**

TDS meters are used to work out how well the reverse osmosis system is running. By measuring the feed water TDS and then measuring the output you can work out the rejection rate.

92% Rejection is OK,

95% Rejection is GOOD

98%+ Rejection is EXCELLENT.

## **MAINTENANCE**

**IT IS IMPERATIVE TO FOLLOW THE SEQUENCE AS OUTLINED**

### **FLUSHING THE SYSTEM WITH THE FLUSH VALVE**

**ALL** RO-MAN systems are fitted with a flush valve, this valve is to extend the life of the membrane, the more often you can put the system in flush mode the better. Daily flushing is best but weekly is ok. All you need to do is open the flush valve for 2-3 minutes each time, this lets the water blast away any build up in the membrane.

### **FILTER CHANGING**

The filters need changing every 1000 gallons of product water or 6 months (whatever one comes first) failure to do so will damage the membrane. Note only use RO-Man replacement parts your guarantees will be void.

- 1.) Turn the water off by slowly turning the saddle valve clockwise.
- 2.) Remove the pre-sediment filter cartridge.
- 3.) Remove the carbon cartridge
- 4.) Install the new filters and re-assemble system.
- 5.) Turn on the system and inspect for leaks.

**CONDITIONS FOR OPERATION**  
**Thin Film Composite Membrane**

<b>Source Water Supply</b>	
Community/Private Non-Chlorinated – or chlorinated as long as the carbon filter is in place and replaced every 6 months or after THE RECOMMENDED gallon throughput, whichever comes first.	
SYSTEM PRESSURE (PRE-FILTRATION)	0 – 75 PSI
MEMBRANE PRESSURE RANGE	40 – 125 PSI
TEMPERATURE	4°-38° C (40°-100° F)
PH RANGE	3.0-13.0
MAXIMUM SUPPLY TDS LEVEL	1500 MG/L
TURBIDITY	<1.0 NET TURBIDITY (NTU)
HARDNESS (CACO.)	<350 MG/L (<20 GPG)
IRON (FE)	<0.1 MG/L
MANGANESE (MN)	<0.05 MG/L
HYDROGEN SULFIDE (H2S)	0.00 MG/L
CHLORINE (CL2)	0.00 MG/L

**Nominal Rejection Characteristics of  
Thin Film Composite Reverse Osmosis  
Membranes**

Calcium	93-99%
Sodium	92-98%
Magnesium	93-98%
Potassium	92-96%
Manganese	96-98%
Iron	96-98%
Aluminium	96-98%
Copper	96-99%
Nickel	96-99%
Cadmium	93-97%
Silver	93-96%
Zinc	96-98%
Mercury	94-97%
Hardness Ca&Mg	93-97%
Radioactivity	93-97%
Chloride	92-98%
Ion	92-98%
Bromide	90-95%
Phosphate	95-98%
Cyanide	90-97%
Sulphate	96-99%
Thiosulfate	96-98%
Silicate	92-95%
Silica	90-98%
Nitrate	90-95%
Boron	50-70%
Borate	30-50%
Fluoride	92-95%
Polyphosphate	96-98%
Orthophosphate	96-98%
Chromate	85-95%
Bacteria	99+%
Lead	95-98%
Arsenic	50-90%

**Reverse Osmosis  
Membranes Performance**

Performance of the reverse osmosis membrane element is affected by two key factors, temperature of the feed water and the net driving pressure across the element. These two factors must be taken into account before comparing or evaluating the performance of the membrane element of a reverse osmosis system

The higher the temperature, the more the product flow and vice versa. All reverse osmosis membrane elements and systems are rated at 77° Fahrenheit (25°Celsius).. To find the membrane permeate rate at different temperatures follow these steps:

Find the t Temperature Correction Factor (TFC) from the table below..

Divide the rated permeate flow at 77° F by the TFC.

The result is the permeate flow at the desired temperature.

Feed Water			Feed Water		
Temperature		Correction	Temperature		Correction
°C	°F	Factor	°C	°F	Factor
5	41.0	2.58	18	64.4	1.29
6	42.8	2.38	19	66.2	1.24
7	44.6	2.22	20	68.0	1.19
8	46.4	2.11	21	69.8	1.15
9	48.2	2.00	22	71.6	1.11
10	50.0	1.89	23	73.4	1.09
11	51.8	1.78	24	75.2	1.04
12	53.6	1.68	25	77.0	1.00
13	55.4	1.61	26	78.8	0.97
14	57.2	1.54	27	80.6	0.94
15	59.0	1.47	28	82.4	0.91
16	60.8	1.39	29	84.2	0.88
17	62.6	1.34	30	86.0	0.85

**Example Question :-** If a thin-film membrane permeate rate at 77 degrees Fahrenheit = 100 gallons/day. What is the permeate rate at 59 degrees Fahrenheit?

**Answer**

Temperature correction factor (from table above) = 1.47 permeate flow at 59 degrees Fahrenheit =  $100 \div 1.47 = 68.03$  gallons (us)/day

### Net Pressure Correction

The membranes used in the systems referred to in these instructions are rated with water at 60 psi pressure and a temperature of 25 degrees Celsius.

To calculate your expected production rate you will first need to establish your expected production at a given temperature as explained previously. This will be called **TCF** =Temperature Correct Flow

Now multiply **TCF** by the membranes rated pressure, which for these membranes is 60psi and then divide by the water pressure from your supply call that **WPS**

So expected production rate will =  $(TCF*60)/WPS$

## TROUBLESHOOTING

It's OK to contact your Retailer or send RO-MAN an email ([HELPDESK@RO-MAN.COM](mailto:HELPDESK@RO-MAN.COM)).

It is best to try first and remember, we cannot see it from here digital photos are great. All problems are fixable and in general they will show up in the first 24-48 hours after the system is fully charged.

1) "I have leakage from a push-in fitting"

Solution: The push-ins rarely leak but on the rare occasion that they do try pushing the line in harder. If this fails take the line out and check the end of the tube. Is it a clean square cut?? If not, take a pair of sharp scissors (or a sharp knife) and cut it then push it in again, firmly.

2) "The system is making water very slowly"

Solution Time in seconds how long it takes to produce exactly one pint of product water. Multiply the measured seconds by 8 to give time in seconds to produce 1 gallon and then divide 86,400 by the time to produce 1 gallon. You now know how many Gallons Per Day(GPD) the system is producing. Make a note of the psi on the pressure meter and take the temperature of your feed water.

Go to [http://www.ro-man.com/ro-man\\_support.html](http://www.ro-man.com/ro-man_support.html) and choose the "System Support " option using the down arrow select your RO-Man system and then input your psi , temperature and if known your input TDS. Click on "Calculate" if the answer to this calculation in UK gallons is markedly higher than what you are producing please contact [HELPDESK@RO-MAN.COM](mailto:HELPDESK@RO-MAN.COM).

Remember that your psi needs to be 40 psi if it is not again please contact [HELPDESK@RO-MAN.COM](mailto:HELPDESK@RO-MAN.COM).

3) "The system is not making water "

Solution This is almost always a psi problem. 40 psi is about as low as you can go. If the psi is low it can be a bad hole on the feed water pipe. try drilling it out.

If you have good psi to the inside of the pre-filters, then check the following:

a) Check to see if the water is flowing out the Green discharge line... if so, then the membrane is getting water.

- b) Disconnect the blue line from the RO membrane housing.... is there any water?
- c) If the Green line is flowing and the blue is not, it may be blocked, check the valve at the RO Housing. There are two outlets on the out end of the RO membrane. One goes to the discharge saddle and the other is purified water. This outlet has a built in check valve inside the chrome plated brass part... take it out ... is there any water there?
- d) If unit has been in service for a while, the problem is probably clogged filters. Pull the filters out, test them one at a time by putting them into the first filter position and seeing if it flows. Clogged filters are usually only associated with well water or with really turbid water.
- e) The RO Membrane has silted up. Very rare unless very bad feed water. The RO Membrane is self-flushing. Try back-flushing the membrane.

#### 4) "My filters are leaking"

Solution Loose O-Ring. Take housing off and make sure they are properly aligned. Housing not tight enough... tighten.

#### 5) "I have leakage from a screw-in connector"

Solution

- a) Not tight enough ... gently apply pressure ... too much and you will strip the threads
- b) If that does not work, remove and apply ptfе tape.

Last tip: nothing lasts forever... The system you bought will wear out. The things that wear out are the RO membrane, ...the flow restrictor and the green line get caked with the junk that is being sent down the drain ... The rubber "O" rings will get old and crack, just like gaskets on your car. If you start replacing them one by one, you are going to go crazy and will spend lots of time and money. A membrane will cost around £40.00 to replace. The bottom line is that it is cheaper and easier just to junk the system (or keep it for parts) and buy a new one every few years, or when the RO membrane dies. You will know when the RO membrane dies ... The water will start tasting bad. We recommend that you invest in a TDS meter and check the TDS of the feed water and the TDS of the RO water. When there is no difference, the RO is dead. It will not happen overnight ... There will be a gradual decay. Remember-change filters every 6 months. If you have fairly heavy duty use, adjust accordingly to fit in with throughput specifications.